

TECHNICAL DATASHEET

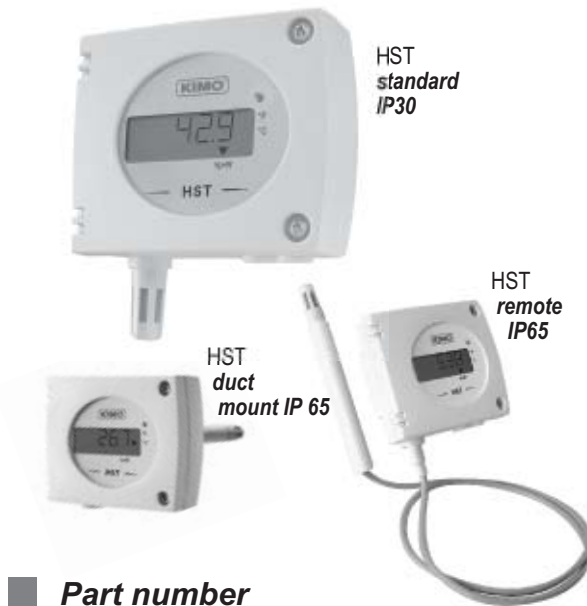

Humidistats

HST



Part number

To order, just add the code to complete the part number :

Probe	
M	Standard
A	Duct mount
D	Remote

HST -

Example : HST-A
Model : humidistats HST with a duct mount probe.

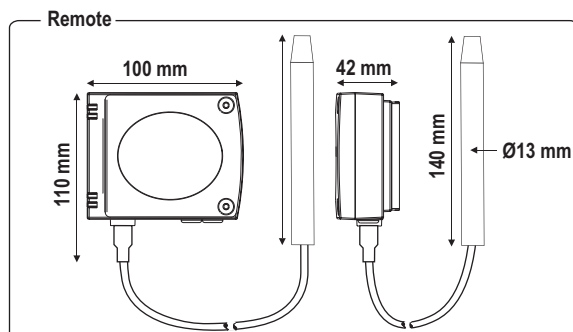
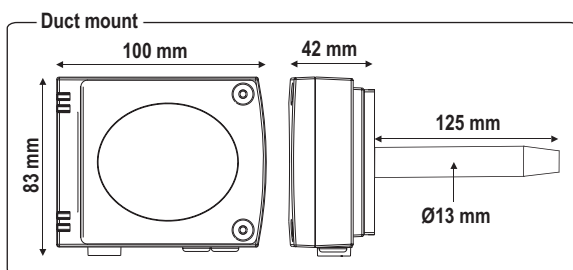
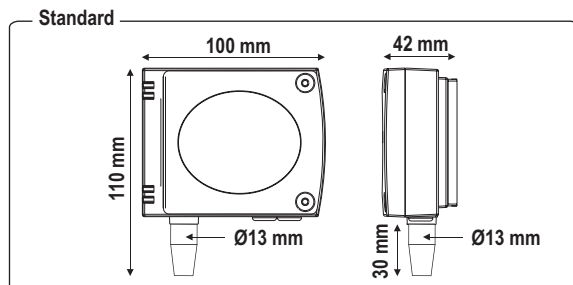

- Measuring ranges from 0 to 100 %RH and 0 to +50°C, -20 to +80°C
- RCR relay 3A/230Vac. Power supply 24Vac/Vdc
- Visual alarm, red LED in front
- IP 65 and IP 30ABS housing, with display
- Alternating display of humidity and temperature
- Quick and easy mounting with the "1/4 turn" system with wall-mount plate

Features of the transmitter

Humidity

Working principle : the measurement of temperature and humidity is made by only one digital component CMOS (complementary metal-oxide semiconductor) including a capacitive element and a thermistor. This technology guarantees an excellent stability in the long term, along with a great accuracy of the measurement.

Measuring range	0 to 100 %RH
Unit of measurement.....	% RH
Accuracy *	±2% of reading ±2%RH in the range of 10 to 90%RH
Response time	1/e (63%) 4 s
Resolution.....	0,1%RH
Type of fluid	air and neutral gases

Temperature

Measuring range.....	0 to +50°C (standard model) -20 to +80°C (duct mount and remote sensor)
Unit of measurement	°C, °F
Accuracy *	±1% of reading ±0,4°C in the range +5 to +80°C ±2% of reading ±0,6°C in the range -20 to +5°C
Response time	1/e (63%) 15 s
Resolution	0,1°C
Type of fluid.....	air and neutral gases

Features of the housing

Housing	ABS
Fire-proof class.....	HB as per UL94
Dimensions	see drawing beside
Protection	IP 30 (standard model) IP 65 (duct mount and remote sensor)
Display	5-digit LCD. Dimensions 50 x 15 mm Alternating display of humidity and temperature.
Height of the digits	10 mm
Cable grip	for cables Ø 7 mm max.
Weight.....	145 g

Technical specifications

Output	1 RCR relay 3A/230 Vac
Relay and alarm status	red LED in front
Set point	2 configurable set points (°C and %RH)
Power supply	24 Vac/Vdc ±10%
Consumption	2 VA
Electro-magnetical compatibility.....	EN 61326
Electrical connection	Screw terminal block for cables Ø1.5mm ² max.
Connection to PC.....	Kimo RS 232 cable
Working temperature(housing).....	0 to +50°C
Working temperature (probe).....	0 to +50°C (standard model) -20 to +80°C (duct mount and remote sensor)
Storage temperature	-10 to +70°C
Environment	air and neutral gases

*All the accuracies indicated in this technical datasheet were stated in laboratory conditions, and can be guaranteed for measurements carried out in the same conditions, or carried out with calibration compensation.

Connection

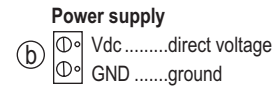
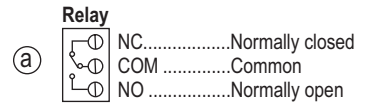
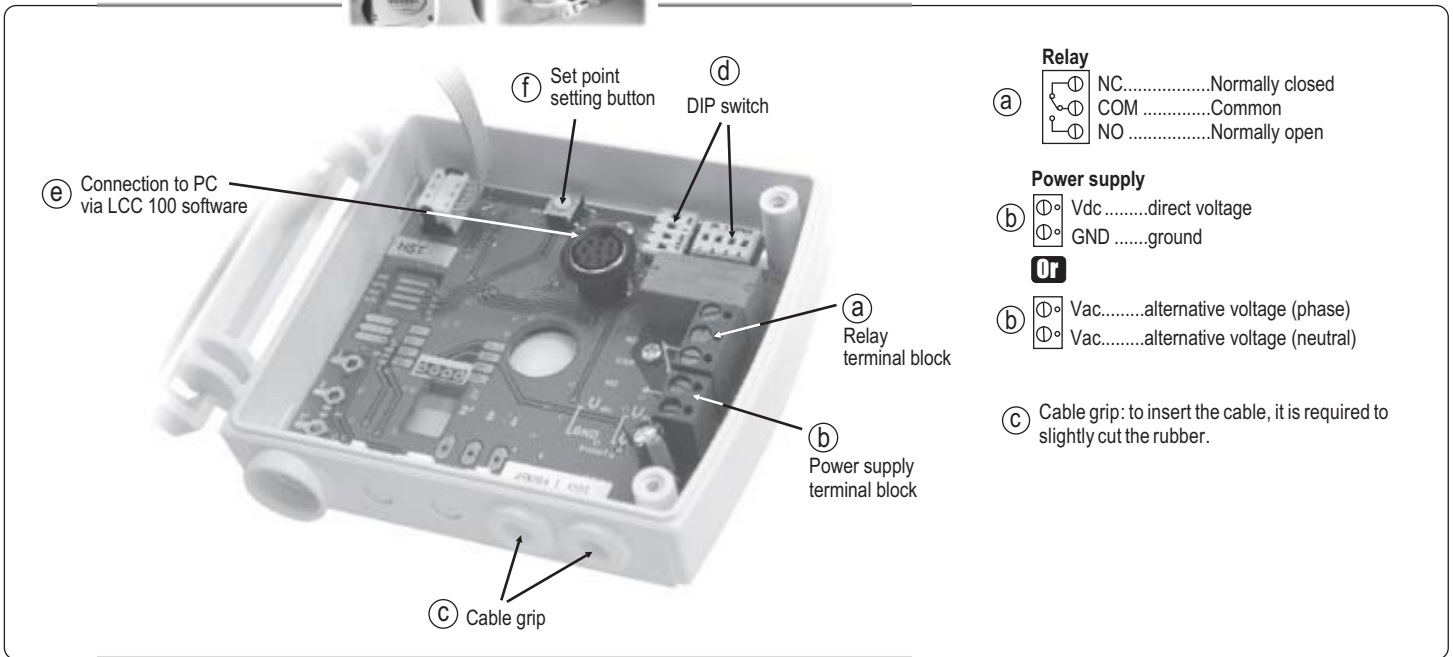

(c) Cable grip: to insert the cable, it is required to slightly cut the rubber.

Electrical connections - as per norm NFC15-100

This connection must be made by a qualified technician. To make the connection, the transmitter must not be energized.

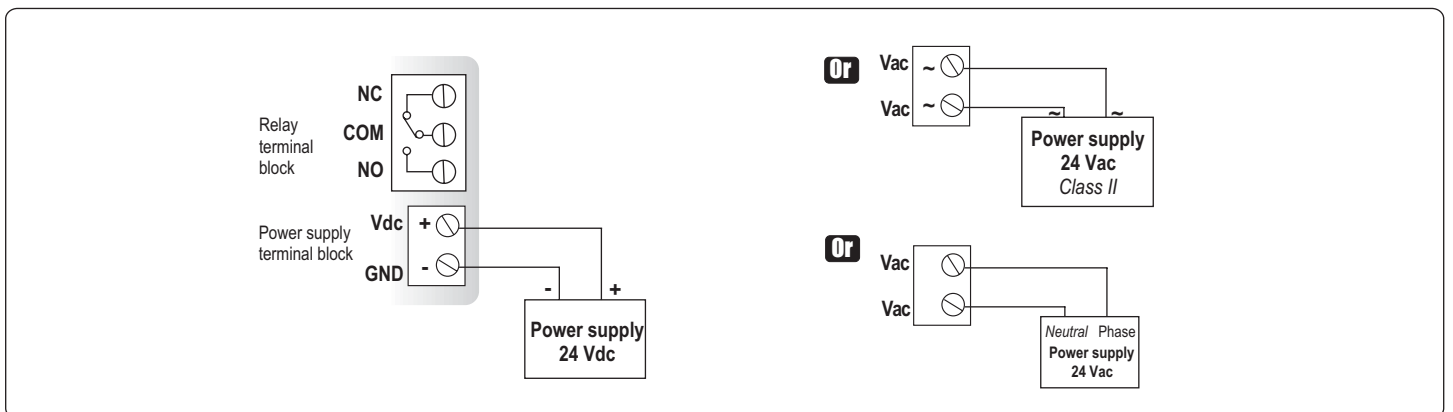

Configuration

Configuration of measuring units, set points can be carried out different ways : **DIP switch, push-button and/or software** (connections (e), (f) and (d) on the drawing "connection").

Configuration of measuring units by **DIP switch**

To configure the transmitter, please unscrew the 2 screws from the housing, and then open it.

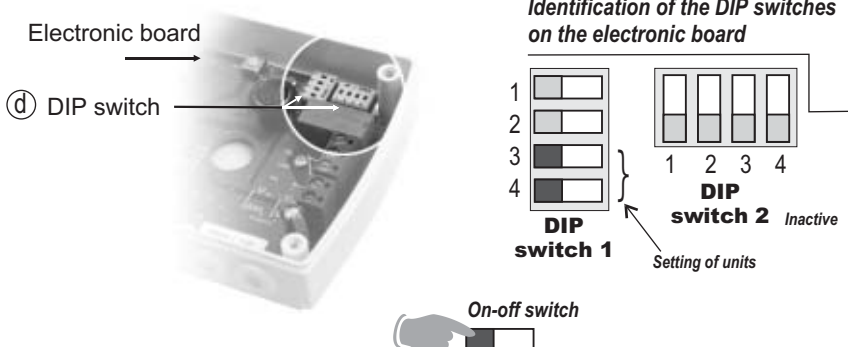

To configure the transmitter, **it must not be energized**. Then, you can make the settings required, thanks to the DIP switches (as shown on the drawing beside). When the transmitter is configured, you can power it up.

Caution !

Please follow carefully the combinations beside with the DIP switch.

If the combination is wrongly done, the following message will appear on the display of the transmitter "CONF ERROR". In that case, you will have to unplug the transmitter, replace the DIP switches correctly, and then power the transmitter up.

•Setting of units

To set the measuring unit, please put the on-off switches 3 and 4 as shown beside.

Configurations	°C	°F
1		1
2		2
3		3
4		4

■ **Set points configuration with the push-button**

Power the transmitter up : it will then display its current configuration. To modify the configuration, please proceed as follows :

- Remove the 2 screws from the housing, and open it.
- The settings are done with the button located on the electronic card (see photo beside).
- For the HST humidistats, the set points configuration is first done for the humidity and then, for the temperature.
- The arrow located on the display is first positioned on “%RH”, the parameters modified are relative to humidity.
- Then, the arrow is positioned on “°C” or “°F”: the parameters modified are relative to temperature.

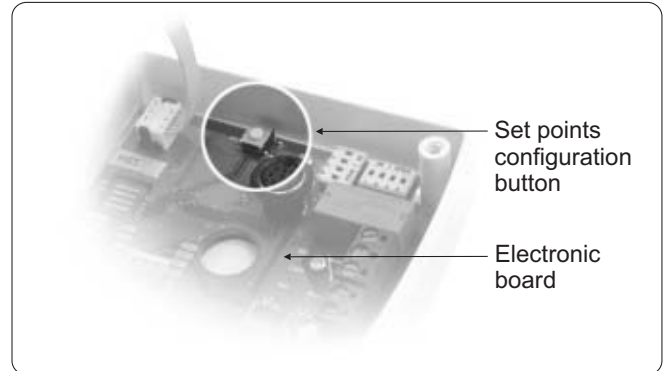

Principle :

- By pressing on this button more than 3 seconds, you can validate the setting and go to the next setting.
- By pressing quickly on this button, you can increment a value and scroll down the different options or values.

This button enables you :

- 1- to activate/deactivate an alarm (set point)
- 2- to set the set point value
- 3- to program the action of the alarm (rising/falling action)
- 4- to set the time-delay (temporisation)

To set the different options :

1- Activating/deactivating the alarm :

After pressing the setpoint configuration button for at least 3 seconds, will be displayed, then or (depending on the configuration of the transmitter).
 Afterwards, by briefly pressing on this button, you can switch between (alarm on) and (alarm off).
 To validate your choice, press again for a duration of 3 seconds. If you chose , then you will exit the configuration mode and switch back to the measurement mode. If you chose , you will move to the next parameter.

2- Programming the set point value :

The set point is a limit which, when being reached and/or exceeded, activates the relay and then the visual red LED alarm.
 The first digit will start to blink, by briefly pressing on the button, you can choose if the set point will be either positive (0) or negative (-). Then press the button during 3 seconds to confirm your choice. The second digit will start to blink. Press the button briefly to change the value. Then press the button during 3 seconds to confirm your choice.
 Repeat this sequence until you have reached the last digit and then confirm the set point.

3- Programming the action of the alarm (rising/falling action) :

the alarm will activate when the measure exceeds the set point
 the alarm will activate when the measure goes below the set point.
 Press the button for 3 seconds to confirm your choice. You will then move on to the last parameter.

4- Setting of the time-delay (dead band temporisation 60 sec max) :

When the set point is reached and/or exceeded, the time-delay will wait the specified time before energizing the relay, if the set point is still reached and/or exceeded.
 When the first digit starts blinking, press briefly on the button to change the value. Then press the button during 3 seconds to confirm your choice. Repeat the process until all digits have the desired value and press the button for 3 seconds to confirm your choice.

The programming is now done and the display will show the current reading.

■ Initialization of the transmitter

When the transmitter is powered up, it initializes and displays the digits $\boxed{0.0.0.0.0}$, and then its configuration including :

- 1 - the measuring range
- 2 - the status of the alarm
- 3 - the set point
- 4 - action of the alarm (rising or falling action)
- 5 - time-delay (dead band temporisation)

1- The measuring range

The following message is displayed : \boxed{Lo} . This is the low value of the measuring range, and its digit value : **ex** : $\boxed{00}$.
 The following message is displayed : \boxed{Hi} . This is the high value of the measuring range and its digit value : **ex** : $\boxed{100}$.
 The arrow displayed (at the bottom or on the right of the screen) is relative to the unit of measurement : **ex** : from 0 to 100 %HR.

2 - The status of the alarm

When the alarm is off, the following message is displayed : \boxed{ALOFF} .
 When the alarm is on, the following message is displayed : \boxed{ALON} .

- When the alarm is off, the transmitter displays $\boxed{----}$, which confirms the end of initialization and that you can start the measurements .
- When the alarm is on, the transmitter displays the parameters relative to the relay (set point, program of the alarm, time-delay).

3 - The set point (alarm on)

This message is displayed : **ex** : $\boxed{50}$, which means that the alarm will be activated as soon as the measurement exceeds this value.

4 - Action of the alarm (rising or falling action)

If the relay is programmed in rising action, the following message is displayed : $\boxed{-f-}$.
 If the relay is programmed in falling action, the following message is displayed : $\boxed{-L-}$.

5 - The time-delay (alarm on)

This message is displayed : $\boxed{15E\zeta}$.
 The temporisation is in seconds (from 0 to 60 sec.).

The transmitter can measure several parameters (HST => humidity + temperature). The transmitter will first display the configuration of humidity parameters, and secondly the configuration of temperature parameters.

After having displayed all the configurations, the transmitter displays $\boxed{----}$, which confirms that the initialization is finished and you can start the measurements.

■ Configuration via software

(with the optional LCC100 software)

An easy and friendly way to configure !

You can configure the measuring units, the set point the time-delay....
 For all the parameters (humidity and temperature)

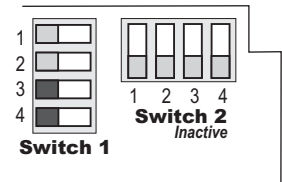

- In order to balance an eventual drift of the transmitter, you can add an offset to the value displayed by the HST :
 => example : the HST indicates 48%RH, the standard reference indicates 45%RH
 => via the LCC100, you can add an offset of "-3" to the value.

To access the configuration via software, you must first position **the DIP switches**, as per the following picture (shown beside), and then connect the cable to the transmitter (see "connection" drawing).

Please refer to the user manual of the LCC 100 to make the configuration.



⚠ Caution !

The configuration can be made either via switch, or via software (you can not combine both solutions).

■ Mounting

Installation : mount the ABS plate on the wall (this plate is supplied with the transmitter). Drilling : $\varnothing 6$ mm, with the screws and pins supplied with the transmitter. Insert the transmitter into the plate (see points A of the drawing shown beside), by tilting it at 30°. Rotate the housing in clockwise direction until you hear a "click" which confirms that the transmitter is correctly installed.

For the model with remote sensor, an additional drilling of $\varnothing 14$ mm must be done before mounting the plate.

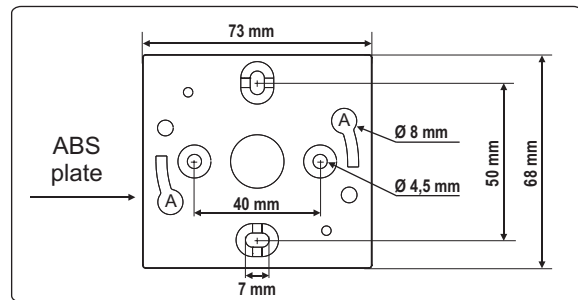

■ Maintenance

Please avoid any aggressive solvent.

Please protect the transmitter and its probes from any cleaning product containing formol, that may be used for cleaning rooms or ducts.

■ Options

- Power supply class 2, input 230 Vac, output 24 Vac, ref.KIAL-100A
- Configuration software LCC 100 supplied with connection RS 232 cable



■ Optional accessories

- Stainless steel sliding connection
- PC connection gland
- ABS clamp with connection gland
- Stainless steel clamp
- Wall-mounting plate for remote humidity probe

EXPORT DEPARTMENT

Tel : + 33. 1. 60. 06. 69. 25 - Fax : + 33. 1. 60. 06. 69. 29
 site : www.kimo.fr e-mail : export@kimo.fr



Distributed by :